



**ATLANTIC CITY ANTIQUE AND COLLECTORS SHOW
ATLANTIC CITY CONVENTION CENTER
MARCH 27 - 28, 2010**



Show Name: ATLANTIC CITY ANTIQUE AND COLLECTORS SHOW

Show Dates: MARCH 27 - 28, 2010

Show Location: ATLANTIC CITY CONVENTION CENTER

Deadline Date To Receive Discounted Rates: MARCH 19, 2010

EXHIBITOR DRIVE-IN HOURS:

THURSDAY	MARCH 25, 2010	8:00 AM - 6:00 PM
FRIDAY	MARCH 26, 2010	8:00 AM - 6:00 PM

EARLY BUYING HOURS

SATURDAY	MARCH 27, 2010	8:30 AM - 10:00 AM
-----------------	-----------------------	---------------------------

PUBLIC SHOW HOURS

SATURDAY	MARCH 27, 2010	10:00 AM - 6:00 PM
SUNDAY	MARCH 28, 2010	10:00 AM - 5:00 PM

EXHIBITOR MOVE-OUT HOUR

SUNDAY	MARCH 28, 2010	5:00 PM - 11:59 PM
---------------	-----------------------	---------------------------

BOOTH EQUIPMENT

Each booth will be provided with an 8' BLACK background drape and 42" BLACK side divider drapes.

ASSISTANCE:

If you have any questions or would like assistance, please call our office at (609) 272-1600.

WE APPRECIATE YOUR BUSINESS



Show Name: ATLANTIC CITY ANTIQUE AND COLLECTORS SHOW

Show Dates: MARCH 27 - 28, 2010

Deadline Date To Receive Discounted Rates: MARCH 19, 2010

ATTENTION **EXHIBITORS**

Please be advised that all of AEX's inventory will be closely monitored. Items are rented and are to be left in your booth at the close of the show.

Thank you

Show Name: ATLANTIC CITY ANTIQUE AND COLLECTORS SHOW

Show Dates: MARCH 27 - 28, 2010

Deadline Date To Receive Discounted Rates: MARCH 19, 2010

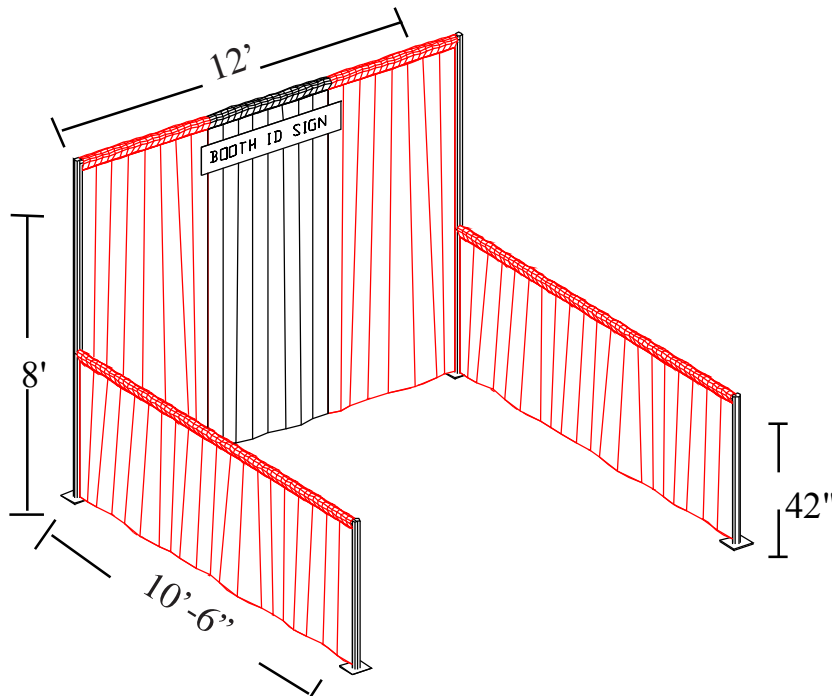

REAR BACKGROUND - 8' HIGH
BLACK

SIDE DIVIDERS - 42" HIGH
BLACK

SIGN
Booth ID sign is 7" high by 44" long.

PIPE AND DRAPE
BOOTH ID SIGN

There is no charge to the exhibitor for this equipment.

AEX Convention Services is pleased to offer services and rentals including; rental furniture; modular exhibits; specialty furniture; grid wall; carpet; perfboards; tack boards; showcases; banners & artwork; floral; photography; labor; forklift and rigging; and, cleaning service etc. If you are interested in service or rentals not in this Exhibitor Kit, please contact our office at (609) 272-1600.

**LIMITS & LIABILITIES AND TERMS AND CONDITIONS
BY USING OUR SERVICES OR SIGNING THE AGREEMENT TO TERMS AND CONDITIONS, YOU AND YOUR
COMPANY AGREE TO THE FOLLOWING**

DRAYAGE/FREIGHT RATES APPLY to each pound with a minimum (see front for actual minimum) and are based on the actual or estimated INBOUND weight. No allowance will be made for during the event. Each shipment is considered separately. NO cumulative weights will be allowed on minimums, split shipments, etc.

SHIPMENTS OF EQUIPMENT REQUIRING SPECIAL HANDLING at the facilities will be subject to a surcharge as indicated on the freight rate schedule. This classification shall be applied to, but not limited to, van shipments or shipments which are packed in such a manner as to require unloading by hand (e.g., loose display parts, uncrated equipment, etc.) Material will be unloaded from vans, exhibitor's truck, or trucks of others at the facility, delivered to the Exhibitor's booth, picked up at the close of the show, moved to the loading area and reloaded. The Exhibitor must provide written and accurate weight information on each shipment. Shipments received without Certified Weight Tickets or Bills of Lading, such as UPS or U.S. Mail, will be delivered to the booth without guarantee of piece count or condition. No liability will be assumed for such shipments.

SPECIAL SERVICES AND RATES - Steel banding for the packing of displays and equipment is available at the AEX Convention Services service desk for \$2.00 per linear ft. plus labor at prevailing rates. Forklifts and drivers are available for spotting equipment in the booth at prevailing rates for equipment and labor. Shrink-Wrap is available at a flat rate of \$45.00 per 4'x4'x4' pallet, thereafter pro-rata.

EMPTY CONTAINER STORAGE - Properly labeled empty containers of freight handled by AEX Convention Services will be removed and returned to the booth; "empty" labels will be available at the service desk. Affixing labels is the sole responsibility of the Exhibitor or representative who must remove or obliterate all old labels. AEX Convention Services assumes no responsibility for removal of containers with old empty storage labels or without AEX Convention Services labels, improper information on empty labels or valuables stored in containers with empty labels. Handling of empty containers of freight not brought in by AEX Convention Services will be charged \$15.00 per box or crate each way.

OUTBOUND SHIPPING INSTRUCTIONS should be given to AEX Convention Services during the event or immediately after its close. All bills of lading and shipping instructions covering outbound shipments will be checked at the time of actual loading and corrections made where discrepancies exist. Freight remaining on the exhibit floor without proper instructions for disposition will be removed by AEX Convention Services and shipped with the information available at the time using a carrier of AEX Convention Service's choice or brought to AEX's warehouse storage and handling will be charged. AEX Convention Services will not be liable for shipping errors subsequent to the event unless it has agreed to specific written instructions has failed to honor them. The condition, count, and contents of the materials found in the booth at the time of actual removal will be final and binding and the right is reserved to alter exhibitor's bill of lading to reflect actual condition, count, and content found.

LIMITATIONS OF LIABILITY - AEX Convention Services IS NOT responsible for damage to materials improperly packed, concealed damage, loss or theft of Exhibitors' material after same has been delivered to your booth, or before materials have been picked up for loading out of the booth. AEX Convention Services makes no warranties or claims except as may be set forth in these terms and conditions. No oral modifications may be made to these terms. Regardless of your claim, AEX Convention Service's liability with respect to your freight or any damage whatsoever, is limited to \$.10 per pound/per article, with a maximum of \$50.00 per item, and a maximum of \$1,000.00 per shipment, even in the event of AEX Convention Service's negligence. AEX's liability for any damages whatsoever when you hire us for supervised installation/dismantle is limited to the actual cost for supervision.

EXHIBIT LOSS OR DISAPPEARANCE - AEX Convention Services and its subcontractors ARE NOT responsible for loss or disappearance of Exhibitor's material after such material has been delivered to the Exhibitor's booth. Relative to inbound shipments, there may be a lapse of time between the delivery of shipment(s) to the applicable booth by AEX Convention Services or its subcontractors, and the arrival of Exhibitor's representative at the booth. During such time the shipment(s) will be left unattended in the booth. AEX Convention Services or its subcontractors shall not be responsible for any loss or damage that may occur during such a period.

Similarly, AEX Convention Services and its subcontractors ARE NOT responsible for loss or disappearance of Exhibitor's material before Exhibitor's material is picked up from the Exhibitor's booth for loading after the exhibition. All bills-of-lading covering outgoing shipment that are given to AEX Convention Services by the Exhibitor will be checked at the time of pick-up from the booth, and corrections will be made at such time if discrepancies exist. Relative to outgoing shipments, it is possible that there will be a lapse of time between the completion of the packing and the pick up material from the booths for loading onto a damage that may occur during such period. AEX Convention Services and its subcontractors are not responsible for any loss or damage that may occur during such period. AEX Convention Services and its subcontractors will adjust the quantities of items on any bill-of-lading submitted to AEX Convention Services or its subcontractors to conform to the actual count of such items in the booth at the time of pick-up and shipment.

DISPUTES - In the event of any dispute between an Exhibitor and AEX Convention Services relative to any loss or damage to such Exhibitor's material, such Exhibitor shall not be entitled to and shall not withhold payment of any amount due to AEX Convention Services for services or rentals provided as any offset against the amount of any alleged loss or damage. Instead, such Exhibitor shall pay AEX Convention Services for any rental or services and Exhibitor may pursue any claim against AEX Convention Services independently. No claims for loss or damage will be considered until payment in full for all services performed by AEX Convention Services has been received.

INSURANCE - Exhibitors agree to carry all-risk floater insurance covering their material against damage, loss, theft and all hazards which covers from the time shipment is made prior to show until shipments are returned to Exhibitor after the show.

We require full payment with order for rentals, service, tax and anticipated freight. This Form, with your credit card information for payment of advance and show site orders, must be completed, mailed or faxed to AEX Convention Services in order for us to provide any rentals or services. Full payment must accompany your order to qualify for the discounted rates. A \$25.00 surcharge will be added to your account if any credit charges are denied or if any checks are returned. Unpaid account will accrue a service charge of 1.5% per month. Exhibitor agrees to be responsible for all fees connected with the collection of its accounts.



FURNITURE RENTAL ORDER FORM

Please Mail or Fax Completed Form to: AEX Convention Services
 3089 English Creek Ave., Egg Harbor Township, NJ 08234
 Fax: (609) 272-1680 • Phone: (609) 272-1600
 www.aexservices.com

Show Name: ATLANTIC CITY ANTIQUE AND COLLECTORS SHOW

Show Dates: MARCH 27 - 28, 2010

Deadline Date To Receive Discounted Rates: MARCH 19, 2010

Company Name: _____ **Booth#:** _____

FURNITURE

Description	Discount	Standard	Qty.	Total
Plastic Side Chair	\$21.00	\$29.50	_____	_____
Padded Arm Chair	\$36.75	\$61.25	_____	_____
Padded Counter Stool	\$40.50	\$67.00	_____	_____
Cocktail Table 42" H	\$65.50	\$67.00	_____	_____
Wastebasket	\$17.50	\$27.25	_____	_____
8' Crossbar	\$25.50	\$40.75	_____	_____
8' Upright with Base	\$26.25	\$42.25	_____	_____

UNDRAPED WOOD TABLES 30" HIGH

Description	Discount	Standard	Qty.	Total
4'L x 24"W	\$26.00	\$50.50	_____	_____
6'L x 24"W	\$35.50	\$47.25	_____	_____
6'L x 30"W	\$36.75	\$59.75	_____	_____
8'L x 24"W	\$39.00	\$61.25	_____	_____
8'L x 30"W	\$42.25	\$65.00	_____	_____

DRAPED DISPLAY TABLES 30" HIGH (Price includes top covered with white plastic and 3 sides draped)

Description	Discount	Standard	Qty.	Total
4'L x 24"W	\$73.00	\$118.50	_____	_____
6'L x 24"W	\$81.00	\$130.50	_____	_____
6'L x 30"W	\$88.00	\$145.50	_____	_____
8'L x 24"W	\$82.25	\$139.75	_____	_____
8'L x 30"W	\$89.50	\$151.75	_____	_____
4th Side Drape 30"	\$15.75	\$26.25	_____	_____

- Please select color:**
- Burgundy
 - Blue
 - Teal
 - Black
 - Purple
 - Gray
 - Gold
 - Green
 - White
 - Red

DRAPES (Drape rates are per linear foot)

Description	Discount	Standard	Qty.	Total
8' Background Drape / lin. ft.	\$18.00	\$32.25	_____	_____
Side Rail Drape 42" h. / lin. ft.	\$14.75	\$26.00	_____	_____

- Please select color:**
- Burgundy
 - Blue
 - Teal
 - Black
 - Purple
 - Gray
 - Gold
 - Green
 - White
 - Red

FURNITURE ORDER TOTAL: \$ _____

YES, I have completed and enclosed the Authorization and Agreement to Terms and Conditions Form and I understand that all orders are subject to New Jersey State Sales tax 7%.



CARPET RENTAL ORDER FORM

Please Mail or Fax Completed Form to: AEX Convention Services
3089 English Creek Ave., Egg Harbor Township, NJ 08234
Fax: (609) 272-1680 • Phone: (609) 272-1600
www.aexservices.com

Show Name: ATLANTIC CITY ANTIQUE AND COLLECTORS SHOW

Show Dates: MARCH 27 - 28, 2010

Deadline Date To Receive Discounted Rates: MARCH 19, 2010

Company Name: _____ **Booth#:** _____

STANDARD BOOTH CARPET

Description	Discount	Standard	Total
9' x 10'	\$87.00	\$156.75	\$ _____
9' x 20'	\$181.75	\$298.50	\$ _____
9' x 30'	\$266.00	\$439.25	\$ _____
9' x 40'	\$350.75	\$580.50	\$ _____

Please select color:

- Black
- Green
- Blue
- Burgundy
- Gray
- Lime Green
- Red
- Teal

Over 9' x 40' available pro rata.

This carpet is not designed to cover complete booth areas since the rental cost does not include seaming and the carpets are not guaranteed to be a color match. If complete exhibit area carpet is desired, see cut & lay section below.

PADDING - PLASTIC COVERING - TAPE

Carpet Padding

_____ ft. x _____ ft. = _____ Sq. ft. @ (Discount \$1.00/sq. ft.)(Standard \$1.25/sq. ft.) = \$ _____

Plastic Covering Area

_____ ft. x _____ ft. = _____ Sq. ft. @ (Discount \$1.35/sq. ft.)(Standard \$1.65/sq. ft.) = \$ _____

Additional Carpet Tape

_____ ft. x _____ ft. = _____ Sq. ft. @ (Discount \$1.80/sq. ft.)(Standard \$2.90/sq. ft.) = \$ _____

(All prices include installation and removal) **SUBTOTAL CARPET RENTAL ORDER:** \$ _____

YES, I have completed and enclosed the Authorization and Agreement to Terms and Conditions Form and I understand that all orders are subject to New Jersey State Sales tax 7%.

PERFBOARD/TACKBOARD RENTAL ORDER FORM

Please Mail or Fax Completed Form to: AEX Convention Services
3089 English Creek Ave., Egg Harbor Township, NJ 08234
Fax: (609) 272-1680 • Phone: (609) 272-1600
www.aexservices.com

Show Name: ATLANTIC CITY ANTIQUE AND COLLECTORS SHOW

Show Dates: MARCH 27 - 28, 2010

Deadline Date To Receive Discounted Rates: MARCH 19, 2010

Company Name: _____ **Booth#:** _____

WHITE TACKBOARD (NOT SHOWN BELOW)

Description	Discount	Standard	Qty.	Total
2' w x 8' h Wings	\$80.00	\$135.25	_____	\$ _____
4' w x 8' h Panel	\$110.00	\$176.75	_____	\$ _____

Select Style:

A B C

WHITE PERFBOARD (SHOWN BELOW)

Description	Discount	Standard	Qty.	Total
2' w x 8' h Wings	\$80.00	\$135.25	_____	\$ _____
4' w x 8' h Panel	\$110.00	\$176.75	_____	\$ _____

Select Style:

A B C

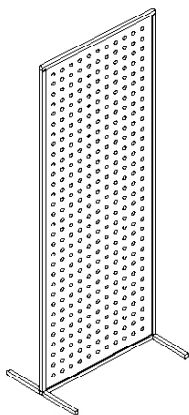

Style "A"
Vertical to Floor

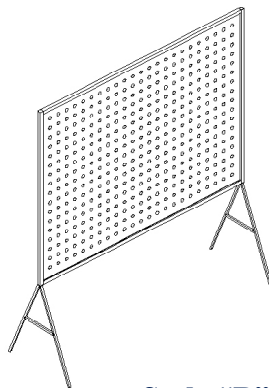

Style "B"
Horizontal off Floor
(30" Off the Floor)

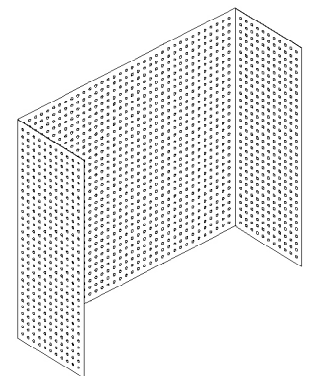

Style "C"
For complete coverage of backwall

Note: Style "C" requires two 4' x 8' panels and three 2' x 8' panels per 10' of backwall. Depth of wings is 2'

Drawings are for illustration purpose only. Legs design may vary.

Please order labor from the "Labor Order Form" for Style "C" or non - standard installations

SUBTOTAL GRID WALL, PERF BOARD & TACK BOARD ORDER: \$ _____

YES, I have completed and enclosed the Authorization and Agreement to Terms and Conditions Form and I understand that all orders are subject to New Jersey State Sales tax 7%.

SHOWCASE RENTAL ORDER FORM

Please Mail or Fax Completed Form to: AEX Convention Services
 3089 English Creek Ave., Egg Harbor Township, NJ 08234
 Fax: (609) 272-1680 • Phone: (609) 272-1600
 www.aexservices.com

Show Name: ATLANTIC CITY ANTIQUE AND COLLECTORS SHOW

Show Dates: MARCH 27 - 28, 2010

Deadline Date To Receive Discounted Rates: MARCH 19, 2010

Company Name: _____ **Booth#:** _____

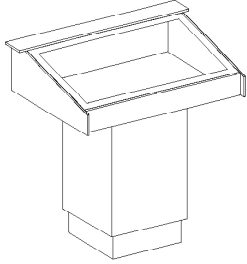

TOP VISION SHOW CASE

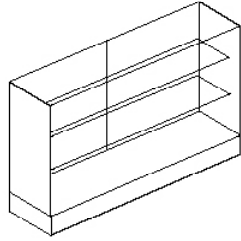

FULL VISION SHOWCASE
(Wood Frame)

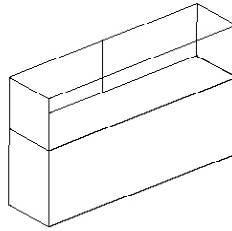

HALF VISION SHOW CASE

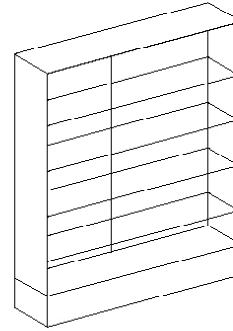

REGULAR WALL CASE

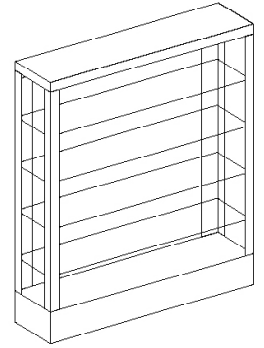

SEE-THRU WALL CASE

Glass shelves are used in these items. To prevent breakage of shelves and articles, good judgement must be used during installation and loading of glass shelves. Take care in placing heavy items or large quantities of items on these glass shelves. A sudden shock, even from small items dropped, can result in broken glass causing personal injury as well as loss of treasured valuables. AEX Convention Services does not assume responsibility for broken glass and/or personal valuables. Rental price includes delivery to and removal from your booth space.

All above are furnished with sliding glass doors and showcase light.

Electrical Orders must be placed with the **ELECTRICAL SERVICE FORM**.

Rental price includes delivery to and removal from your booth space.

Type	Qty.	Discount	Standard	Total
Top Vision Showcase 49" H x 39" D x 43" W	_____	\$260.00	\$437.00	_____
Full Vision Showcase 38" H x 18" D Please select 60" Wide or 72" Wide	_____	\$281.00	\$475.50	_____
Half Vision Showcase 38" H x 20" D Please select 60" Wide or 72" Wide	_____	\$281.00	\$475.50	_____
Regular Wall Case 84" H x 18" D x 70" W	_____	\$293.50	\$497.25	_____
See-Thru Wall Case 84" H x 18" D x 70" W	_____	\$299.75	\$507.00	_____
Additional Shelves	_____	\$20.00	\$35.75	_____
Locks	_____	\$26.50	\$39.50	_____

****PLEASE NOTE: THE SHOWCASE LOCATION FORM MUST BE COMPLETED ALONG WITH THIS FORM****

Show Case & Wall Case Colors:

Please indicate your selection by 1st, 2nd & 3rd color choice below:

(A) Walnut/Almond (B) Black/Black (C) Black/White (D) White/White

1st Color Choice _____ 2nd Color Choice _____ 3rd Color Choice _____

IMPORTANT: AEX CONVENTION SERVICES will not be liable for contents, damages, or breakage after the cases have been delivered to the booths.

We will do our best to honor your selection. Priority will be given in date received/paid order. Deadline for discount/advance orders is MARCH 19, 2010 with full payment. ALL ORDERS ARE SUBJECT TO AVAILABILITY.

SUBTOTAL SHOWCASE RENTAL ORDER: \$ _____



SHOWCASE LOCATION FORM

Please Mail or Fax Completed Form to: AEX Convention Services
3089 English Creek Ave., Egg Harbor Township, NJ 08234
Fax: (609) 272-1680 • Phone: (609) 272-1600
www.aexservices.com

Show Name: ATLANTIC CITY ANTIQUE AND COLLECTORS SHOW

Show Dates: MARCH 27 - 28, 2010

Deadline Date To Receive Discounted Rates: MARCH 19, 2010

Company Name: _____ **Booth#:** _____

Rental of the showcase includes a one time spotting service AT THE TIME OF DELIVERY. Please indicate on the diagram below the exact positioning of the unit. Should you request a second spotting, AEX Convention Services will charge you for that service at prevailing labor rates.



FRONT OF BOOTH

CAUTION TO EXHIBITOR

Glass shelves used in this item are of Premium Quality glass. To prevent breakage of shelves and articles, good judgment must be used during installation and loading of glass shelves. Take care in placing heavy items or large quantities of items on these shelves. A sudden shock, even from a small item being dropped, can result in broken glass causing personal injury as well as loss of treasured valuables. Because the end use of the item is beyond our control AEX Convention Services cannot assume responsibility for broken glass and/or personal valuables.

FOR OFFICE USE ONLY:

1 OF _____

STYLE: _____

AC Antique & Collectors Show
 March 27th & 28th 2010
 Atlantic City, NJ
 Show # 7711

ELECTRICAL SERVICE ORDER FORM

COPY FOR YOUR RECORDS



ELECTRICAL

Full payment is required to process order. Return with 100% remittance to:

ACCC Electrical • One Convention Boulevard • Atlantic City, NJ 08401 USA • Phone (609) 449-2291 • Fax (609) 449-2464 FED ID#232511871
IF YOU FAX YOUR ORDER PLEASE PRINT OUT A FAX CONFIRMATION FOR YOUR RECORDS.

COMPANY		BOOTH NUMBER	
ADDRESS	Street	city	state zip country
PHONE	FAX		PURCHASE ORDER NUMBER
AUTHORIZED CONTACT SIGNATURE		AUTHORIZED CONTACT • PLEASE PRINT DATE	
<input type="checkbox"/> MASTERCARD <input type="checkbox"/> VISA <input type="checkbox"/> AMERICAN EXPRESS EXPIRATION DATE			
ACCOUNT NUMBER			
CARDHOLDER SIGNATURE	CARDHOLDER'S NAME • PLEASE PRINT		

**ADVANCE RATE DEADLINE DATE:
 March 19th 2010**

By signing and delivering this form to ACCC Electrical, customer agrees to all terms and conditions printed on this form.
We do not accept orders without payment.

QUANTITY NON-24 HR	DESCRIPTION	ADVANCE RATE	REGULAR RATE	TOTAL
120 V LIGHTING & UTILITY OUTLETS				
	Up to 1000 watts	\$ 120.00	\$ 180.00	
	Up to 2000 watts	\$ 150.00	\$ 225.00	
208V 1Ø MOTOR AND EQUIPMENT OUTLETS				
<i>All 208V connections require labor which will be billed at show.</i>				
	20 Amp	\$ 320.00	\$ 480.00	
	30 Amp	\$ 390.00	\$ 585.00	
	60 Amp	\$ 680.00	\$ 1020.00	
	100 Amp	\$ 845.00	\$ 1270.00	
	200 Amp	\$ 1320.00	\$ 1990.00	
208V 3Ø MOTOR AND EQUIPMENT OUTLETS				
<i>All 208V connections require labor which will be billed at show.</i>				
	20 Amp	\$ 395.00	\$ 590.00	
	30 Amp	\$ 465.00	\$ 690.00	
	60 Amp	\$ 745.00	\$ 1100.00	
	100 Amp	\$ 895.00	\$ 1300.00	
	200 Amp	\$ 1550.00	\$ 1950.00	
TRANSFORMER(S)				
Circle Outlets Requiring Boost				
	Boosts 208V to 230V	\$ 165.00	\$ 230.00	
480V 3Ø MOTOR AND EQUIPMENT OUTLETS				
<i>All 480V connections require labor which will be billed at show.</i>				
	30 Amp	\$ 870.00	\$ 1300.00	
	60 Amp	\$ 1120.00	\$ 1635.00	

ACCCE is not responsible for voltage fluctuation or power failure due to temporary conditions. For your protection you should install a surge protector on your equipment. All electrical installations and connections to all electrical service should be made by an ACCCE electrician. ACCCE will not be responsible for any damage or loss to any equipment component, computer hardware or software and/or any damage or injury to any person caused by the installation, connection or plugging in of any electrical outlet by an ACCCE electrician.

IMPORTANT

- 24-hour Power & Dedicated Circuits will be double the listed price. Please double rates. Use * to indicate 24-HR outlet(s).
- To receive the advance rate, we must receive your order, along with payment in full or credit card authorization, on or before deadline date. All other orders will be charged at the regular rate.
- No credits will be issued on unused outlets or lights installed as ordered. Claims regarding services provided by ACCCE can not be considered unless filed by the exhibitor prior to the close of show. Cancellations must be faxed to our office three days prior to show move in. There will be a 25% surcharge on all cancellations.
- Electricity will be turned on within 30 minutes of show opening and off within 30 minutes after show closing.

OUTLET LOCATION & DISTRIBUTION

- All 110 volt electrical outlets will be installed on the floor at the draped backwall of inline and peninsula booths.
- All 110 volt electrical outlets for island booths will be set at one main location on the perimeter of the booth at our discretion if no floor plan provided. Labor is necessary in all Island booths.
- Any additional power locations are chargeable on a time and material basis.
- Distribution and connection of outlets are chargeable on a time and material basis. Please call regarding placement of 208 volt outlets.
- All services larger than 100 amps may be subject to an additional labor charge.

ACCC ELECTRICAL JURISDICTION
 (Requires labor and/or material)

ELECTRICAL LABOR

- Labor rates are subject to labor contract effective at time of show.
- Labor before 8:00am and after 4:30pm and Saturdays, Sundays and holidays will be at the overtime rate.
- Electricity Labor Rates: \$108.00 per hour Regular Time, \$216.00 per hour Overtime. Labor is billed in half-hour increments with a minimum of one hour. Dismantle labor is half that of the total installation labor. Overtime labor will be charged for shows closing @ 2pm.
- Forklift Rates: prevailing labor rates (one hour minimum) plus \$250.00 forklift rental.
- Starting time can only be guaranteed when labor is requested for the start of the working day at 8:00am. The minimum charge per booth is one hour for installation and one-half (1/2) hour for dismant. Time will commence per exhibitor's request. Failure to start labor at requested time will result in a one hour charge per electrician requested, unless 24-hour advance notice is provided in writing.

Supervision is required on larger or Island booths.

- All under-carpet distribution of electrical wiring.
- All distribution, light hanging or general labor in any space larger than 200 sq. ft.
- All facility overhead distribution of electrical wiring, including coaxial cable, fiber optics, twisted pair, etc., and the distribution of same from product to booth and from booth to booth.
- All connections requiring 208 volts and above.
- All motor and equipment hook-ups requiring hard wiring connections.
- Installation and/or repair of electrical fixtures.
- Installation of all computers.
- Installation of electrical motors and electrical apparatus to be energized.
- All electrical signs and headers.
- Labor is required to inspect equipment pre-wired to plug into our system.
- Exhibitors are not permitted to use power unless ordered. Exhibitors found using outlets without an order will be subject to the regular rate for outlets used.

Rigging: Please call for quote.

FLOOD LIGHTS

Price includes outlet and labor (for track and flood lights only.) Placement of floodlights is at the front corner(s) of your in-line booth.

Any other location(s) or installation time will require an additional labor charge.

	120 Watt	\$ 105.00	\$ 150.00	
	Dbl 120 Watt	\$ 135.00	\$ 205.00	
	250 Watt Krypton	\$ 140.00	\$ 210.00	
	Overhead Quartz*	\$ 355.00	\$ 540.00	

TRACK LIGHTS Not available in all locations on the show floor.

	4' Track w/3 Lights	\$ 154.00	\$ 245.00	\$
	Add'l 50 Watt Halogen	\$ 43.00	\$ 68.00	

1. SUB TOTAL	\$
2. SALES TAX 7%	\$
3. PAYMENT ENCLOSED	\$

***REQUIRES LABOR AND/OR LIFT AT ADDITIONAL CHARGE NOT AVAILABLE AT SOME LOCATIONS. FLOOR PLAN IS REQUIRED FOR QUARTZ LIGHTS.**

Important information on reverse side.

ALL CONNECTION AND LABOR RATES SUBJECT TO CHANGE.

LABOR REQUEST FOR ELECTRICAL DISTRIBUTION:

Date: _____ Time: _____

This Labor order will not be processed until we receive a completed electrical order, credit card authorization, and or floor plan. Please indicate neighboring booth and aisle numbers.

DO NOT Proceed – Exhibitor Will Call For Labor

OK to Proceed Without Supervision – Per Attached Floor Plan

METHOD OF PAYMENT

Check Enclosed: No: _____ Credit Card Provide Information Above

Your credit card authorization is required for labor and material charges. For your convenience we will also charge the card for any additional amounts incurred as a result of showsite orders placed by you or your representative. All returned checks are subject to a \$30.00 fee.

AC Antique & Collectors Show
 March 27th & 28th 2010
 Atlantic City, NJ
 Show # 7711

**TELECOM & INTERNET
 SERVICE ORDER FORM**
 COPY FOR YOUR RECORDS



Full payment is required to process order. Return with 100% remittance to:

ACCC Utilities • One Convention Boulevard • Atlantic City, NJ 08401 USA • Phone (609) 449-2291 • Fax (609) 449-2464 FED ID#232511871
IF YOU FAX YOUR ORDER PLEASE PRINT OUT A FAX CONFIRMATION FOR YOUR RECORDS.

COMPANY		BOOTH NUMBER			ADVANCE RATE DEADLINE DATE: March 19th 2010 <i>By signing and delivering this form to ACCC Utilities, customer agrees to all terms and conditions printed on this form. Orders submitted without payment will not be processed.</i>
ADDRESS	STREET	CITY	STATE	ZIP COUNTRY	
PHONE	FAX		PURCHASE ORDER NUMBER		
AUTHORIZED CONTACT SIGNATURE		AUTHORIZED CONTACT • PLEASE PRINT		DATE	
<input type="checkbox"/> MASTERCARD <input type="checkbox"/> VISA <input type="checkbox"/> AMERICAN EXPRESS		EXPIRATION DATE			
ACCOUNT NUMBER					
CARDHOLDER SIGNATURE		CARDHOLDER'S NAME • PLEASE PRINT			
QUANTITY	DESCRIPTION	ADVANCE RATE	REGULAR RATE	TOTAL	Dates of Service _____
BASIC PHONE LINE (includes dial 9, for voice/fax/modem, unrestricted Phone line & instrument)					
	Basic phone line	\$245.00	\$290.00		
	Hunt/Rollover & Toll restriction (price per service)	\$11.00	\$11.00		

ISDN DATA LINES – (ISDN modem/equipment required)- not recommended for Internet access					
	BRI-ISDN (1-B channel – 64K)	\$310.00	\$465.00		
	BRI-ISDN (2-B channel – 128K)	\$420.00	\$630.00		

INTERNET CONNECTION – utilizing 10MB Ethernet connection to fiber optic backbone with RJ45 twisted pair connection to the booth (Network Interface Card (NIC) required) PLEASE RUN UPDATED ANTI VIRUS SOFTWARE ON YOUR COMPUTER BEFORE YOUR ARRIVAL AT THE FACILITY.***					
	One IP Address	\$520.00	\$780.00		
	Add'l IP Address @ same location (within same booth or mtg. Room)	\$184.00	\$276.00		

LAN CONNECTIONS (within booth, booth to booth, booth to mtg. Room) (does not include internet connectivity)					
	LAN-10MB Ethernet	\$363.00	\$544.00		
	Add'l LAN 10MB at same location	\$79.00	\$119.00		
	LAN-100MB Ethernet	\$394.00	\$591.00		
	Add'l LAN 100MB at same location	\$84.00	\$126.00		

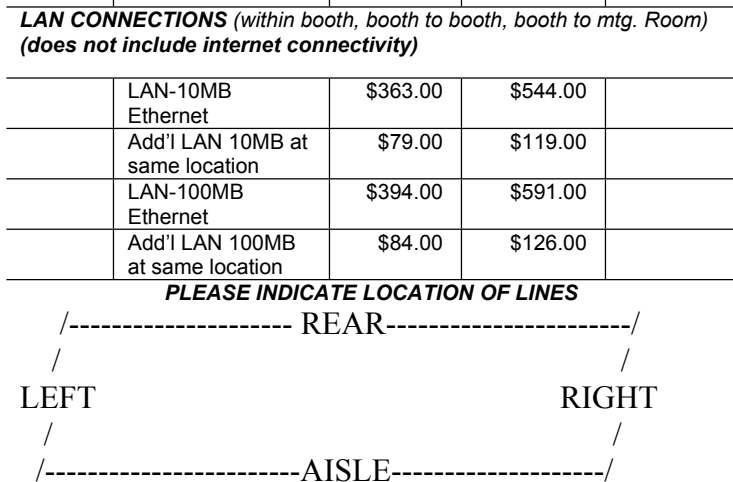

IMPORTANT

- Outgoing phone calls will be billed at the following rates: Local: \$.07/min., long distance \$.46/min., Toll free \$.50 per call.
- To receive the advance rate, we must receive your order, along with payment in full or credit card authorization, on or before deadline date. All other orders will be charged at the regular rate.
- In order to process orders in advance, locations of connections must be indicated (see diagram below). For meeting room connections, a detailed floor plan must be included. Failure to indicate location will result in your line being placed in rear of booth and/or may result in delay of service or add'l charges.
- No credits will be issued on unused phone lines installed as ordered. Only written cancellations will be accepted and must be received seven days before show move in.

TERMS & CONDITIONS

- The ACCC is the exclusive provider of telecommunications for the Atlantic City Conv. Center.
- Exhibitors should pick up phone instruments at the Telecomm. Service desk.
- Exhibitors will be responsible for the protection and return of any equipment rented from ACCC. Equipment should be returned to the Service Desk at the close of the event.
- A \$100 per single line set charge and a \$300 multi-line set charge will be billed to your credit card if sets are damaged or not returned.

- A detailed statement of calls will be invoiced at the conclusion of the show and charged to the credit card provided. Credit card receipts and detail of calls will be mailed to the exhibitor.
- Telecommunications panels, floor boxes and equipment must be accessible at all times. Panels, floor boxes and equipment shall not be rendered inaccessible to ACCC Telecom personnel.
- Unless otherwise directed, ACCC techs are authorized to cut floor coverings. Telephone service is provided from floor boxes on 30-ft. centers.
- ACCC is responsible for Internet and other ACCC installed cable connections from point of demarcation to exhibitor booth. Services are limited to cable installation and IP address assignment. It is the responsibility of the exhibitor to supply connectors, connect cable to exhibitor equipment, configure exhibitor equipment and properly operate equipment. ACCC will troubleshoot ACCC installed components only.
- ACCC is not responsible for lost connections or traffic interruptions. We will work with third parties to resolve circuit issues on a best effort basis. No refunds or discounts will be given for service interruptions or other network service related downtime.
- *** THE ACCC IS NOT RESPONSIBLE FOR SERVICE INTERRUPTION DUE TO VIRUS INFECTION.**
- The exhibitor must file disputes concerning service with the Service desk prior to the close of the event.
- A minimum of \$50 will be charged to move an installed line.
- Prices subject to change without notice.
- ACCC does not allow the construction of wireless networks in the Facility.

1. SUB TOTAL	\$
2. SALES TAX 7%	\$
3. PAYMENT ENCLOSED	\$

FOR OFFICE USE ONLY:

Exh. No. _____ Phone Ext. #: _____

Payment: _____ Date Rec'd: _____

THE SAFE MAN, LLC

Safe Sales & Rental

209 Wood Avenue

Middlesex, NJ 08846

800-320-2589 / 732-302-1118

732-302-1119 Fax

Thesafemanllc@aol.com

24 Hr. Help 908-963-1572 Addie's cell

*****There is a limited amount of safes per model*****

Model	Description	Cubic Ft.	Inside Dimensions "H x "W x "D	Outside Dimensions "H x "W x "D	Approx. Weight Lbs.	Weekend Rental ***
2115-2	2hr. fire 2 shelves	3.2	20 x 18.5 x 15	31.5 x 25.5 x 21	420	\$280
3115-2	2hr. fire 2 shelves	4.9	30.5 x 18.5 x 15	41 x 25.5 x 21	525	\$300
3921-2	2hr. fire 2 shelves	8.9	39.5 x 18.5 x 21	50 x 25.5 x 27	760	\$320
5021-2	2hr. fire 3 shelves	11.2	50 x 18.5 x 21	60.5 x 25.5 x 27	875	\$350
6030	Burglary & fire 4 shelves	14.6	55 x 25.5 x 18	60 x 30 x 26	885	\$400
3524	TL 30 / 2 hr. fire 2 shelves	9.7	35 x 24 x 20	42 x 31 x 30	1,765	\$450
5524	TL30 / 2 hr. fire 3 shelves	15.3	55 x 24 x 20	62 x 31 x 29.5	2,475	\$550
6528	TL 30 / 2 hr. fire 4 shelves	21.1	65 x 28 x 20	72 x 35 x 29.5	3,200	\$700
6835	TL 30 / 2 hr. fire 5 shelves	32.9	68 x 35 x 25	72 x 42 x 36	4,500	\$1000
COVER RENTAL BLACK CLOTH COVER					\$25	

*** Week Rental price apply only if rented safe is delivered and picked up M-F 8:00am-5:00pm. Other fees apply if special time or holiday arrangements are needed. Some shows may apply a Teamster Charge (not included).



THE SAFE MAN, LLC

209 Wood Ave.

Middlesex, NJ 08846

THESAFEMANLLC@AOL.COM

Phone (800) 320-2589 / 732-302-1118

Fax (732) 302-1119

PLEASE, DRAW THE SAFE INSIDE THE BOOTH, WITH THE TRIANGLE BEING THE DOOR

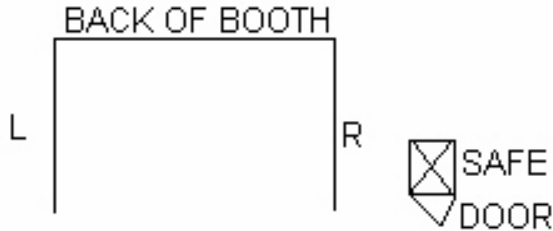

<i>Company:</i>		<i>Booth #</i>	
<i>Contact:</i>		<i>Phone:</i>	
<i>Address:</i>		<i>Fax:</i>	
<i>City:</i>		<i>State:</i>	<i>Zip:</i>
<i>Email:</i>			
Qty.	Description		Price Total
1	WEEK/END SAFE RENTAL		
****	SAFE MODEL		
****	A CONFIRMATION OF THE ORDER WILL BE FAXED OR EMAILED. OPTIONS WILL BE GIVEN IF REQUEST IS NOT AVAILABLE.		
	CREDIT CARD#:		
	EXPIRATION		
	SECURITY CODE:		
TOTAL			
SHOW:			
DELIVER ON		PICK UP ON	
SAFE LOCATION IN BOOTH:(DRAW UP TOP OR DESCRIBE BELOW)			

Signature _____

A \$25.00 fee will be charged for missing keys at the end of the show. Make sure you leave your key in or on the safe. If a cover is rented, please leave inside lockes safe as well (\$150.00) Thank you!